

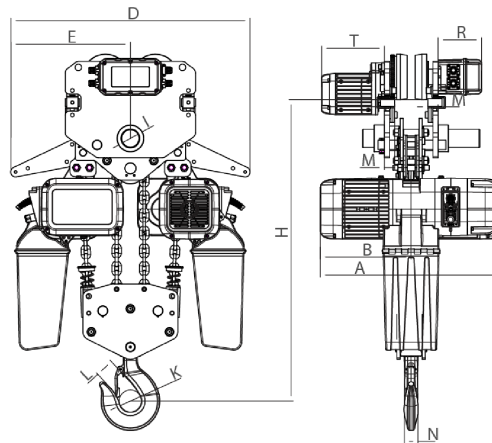

**10 ton Electric Chain Hoist w/
Power Trolley Variable Speed
Trolley 380V 3 ϕ , 50HZ 40ft G100
Nickel Duty H4/M5**

Especificaciones Técnicas

Plug	Open Leads	Capacidad de Carga	10 ton
Altura de Izaje Estandar (Customizable)	40 ft / 12 m	Velocidad /min	10.63 ft @60Hz 2.70 mt @50Hz
Numero de Velocidades	1 Speed	Voltaje	3 Phase 380V 50Hz
Clase de Servicio	H4/M5/2m/Class D	Protección IEC Motor	IP55
Control	Pendant Control IP66	Voltaje del Control	24V
Tipo Transmisión / Reductor	Spur gearbox	Tipo de Cadena	G100 Nickel
Dimensiones de la Cadena	11.2 mm	Caidas de Cadena	4
Longitud de cadena	160	Humedad	20%~90%
Temperatura	-4 ~ 104° F / -20 ~ 40° C	Potencia del Trolley	750
Velocidad del Trolley /min	2.75~27.55 ft @60Hz 0.7~7 mt @50Hz	Cantidad de Velocidades	Variable
Normas	ASME HST-1 , ASME B30.16 , B30.17 , EN60204-38	Garantía	3 Year
Hoist Contactors Amps	25A	Hoist Contactor Brand	Schneider
Hoist Contactor Model	LC1D25B7C	Hoist Contactor Coil Voltage	24 V
IEC Hoist IP Protection	IP55	Pendant Control Yes No	Yes
IEC Pendant Control Protection	IP66	Pendant Control Emergency Stop	Yes
Pendant Control total Length	37 ft	Hoist Motor Power in KW	3+3
Hoist Motor Brake Type and DC Voltage	DC170V	Overload Protection	Overload Motor Clutch
Hour Meter	Internal Working Hour Meter	Brake rectifiers-half-wave	PWRX-BKTF-HW
Hoist Motor Insulation Grade	F	Recommended Hoist Protection Circuit Breaker AMPs and Type	Type D 30A
Optional Load Chain Brand & Country of Origin	FEC Japan	Reducer Lubrication Type	Oil
Paint Specifications	Electrostatic Sprayed Plastic (ESP) Epoxy resins, Polyester Resins, Barium, Pigments	Trolley Motor Brake Type and DC Voltage	DC170V
Trolley Motor Insulation Grade	F	Trolley VFD Power in KW	2.5kW
Trolley VFD Brand	Huayuan	Trolley VFD Model	Z230
Trolley Wheel Diameter	139	Trolley Wheel Material	No. 45 steel
Trolley Minimum Turn Radius	2 m / 6.5 ft	Trolley Beam Range	3.9" to 7"
Trolley Beam Extension Kit	up to 12"	Load Chain weight per foot [lbs]	1.83
1st Package Type	Wood Crate	2nd Package Type	Wood Crate



Rated load (t)	Type	Dimension (mm)													
		Minimum distance from the bottom of the track to the bottom hook: H	A	L	B	D	E	I	M	N	K	L	T	R	
10	PWRXT10-04	1045	700	3500-5500	350	920	460	70	39	48	85	80	242	167	

Peso & Dimensiones

Peso Total 869 lbs / 395 Kg

Detalles del Empaque

H Altura Muerta 39.57

A Altura Total 41.14

D Depth 27.56

W Ancho 36.22

J Boca Gancho 3.35

Peso Total (sin cable o cadena) 697.88

Referential Images / Imágenes Referenciales
Specifications may change without notice / las especificaciones pueden cambiar sin previo aviso