

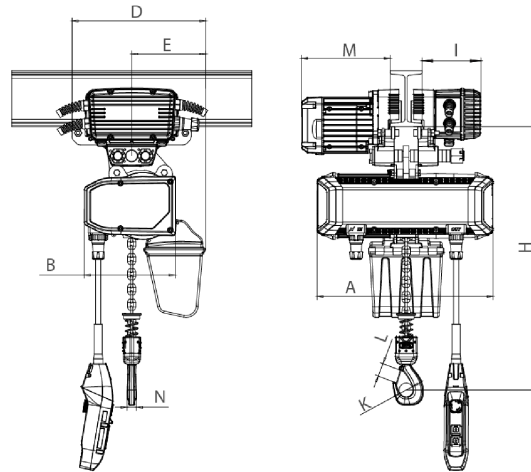

**1/2 ton Electric Chain Hoist w/  
Power Trolley Variable Speed 380V  
3Ø 50~60HZ**

## Especificaciones Técnicas

Capacidad de Carga	1/2 ton	Plug	Open Leads
Altura de Izaje Estandar (Customizable)	13 ft / 4 m	Velocidad /min	ft @60Hz 1~8 mt @50Hz
Numero de Velocidades	Variable Speed	Voltaje	3 Phase 380V 50Hz
Clase de Servicio	H4/M5/2m/Class D	Protección IEC Motor	IP55
Control	Pendant Control IP66	Voltaje del Control	24V
Tipo Transmisión / Reductor	Spur gearbox	Tipo de Cadena	G100 Nickel
Dimensiones de la Cadena	6.3mm	Caidas de Cadena	1
Longitud de cadena	13 ft (4 m)	Humedad	20%~90%
Temperatura	-4 ~ 104° F / -20 ~ 40° C	Potencia del Trolley	500
Velocidad del Trolley /min	5.9~47.23 ft @60Hz 1.5~12 mt @50Hz	Cantidad de Velocidades	Variable
Normas	ASME HST-1 , ASME B30.16 , EN60204-37	Garantía	3 Year
Hoist VFD Brand	HUAYUAN	Hoist VFD Power	1.5kW
VFD Model	Z230	Brake Resistor Kw	0.3Kw
IEC Hoist IP Protection	IP55	Pendant Control Yes No	Yes
IEC Pendant Control Protection	IP66	Pendant Control Emergency Stop	Yes
Pendant Control total Length	10 ft	Hoist Motor Power in KW	0.75
Hoist Motor Brake Type and DC Voltage	DC170V	Overload Protection	Overload Motor Clutch
Hour Meter	Internal Working Hour Meter	Brake rectifiers-half-wave	PWRX-BKTF-HW
Hoist Motor Insulation Grade	F	Recommended Hoist Protection Circuit Breaker AMPs and Type	Type C 4A at 380V
Optional Load Chain Brand & Country of Origin	FEC Japan	Reducer Lubrication Type	Oil
Paint Specifications	Electrostatic Sprayed Plastic (ESP) Epoxy resins, Polyester Resins, Barium, Pigments	Trolley Motor Brake Type and DC Voltage	DC170V
Trolley Motor Insulation Grade	F	Trolley VFD Power in KW	2.5kW
Trolley VFD Brand	Huayuan	Trolley VFD Model	Z230
Trolley Wheel Diameter	95	Trolley Wheel Material	No. 45 steel
Trolley Minimum Turn Radius	1.3 m / 4.2 ft	Trolley Beam Range	3" to 5"
Trolley Beam Extension Kit	up to 12"	Load Chain weight per foot [lbs]	0.58
1st Package Type	Wood Crate	2nd Package Type	Wood Crate



Rated load (t)	Type	Dimension (mm)									
		Minimum distance from the bottom of the track to the bottom hook: H	A	L	B	D	E	I	M	N	K
0.25-0.5	PWRXT0.25-0.5-VS	473	447	3500-5500	217	334	152	147	220	20	35

## Peso & Dimensiones

<b>Peso Total</b>	156.2 lbs / 71 Kg
-------------------	-------------------

## Detalles del Empaque

<b>H Altura Muerta</b>	15.59
<b>A Altura Total</b>	15.59
<b>D Depth</b>	17.32
<b>W Ancho</b>	12.01
<b>J Boca Gancho</b>	1.38
<b>Peso Total (sin cable o cadena)</b>	113.49

Referential Images / Imágenes Referenciales

Specifications may change without notice / las especificaciones pueden cambiar sin previo aviso