

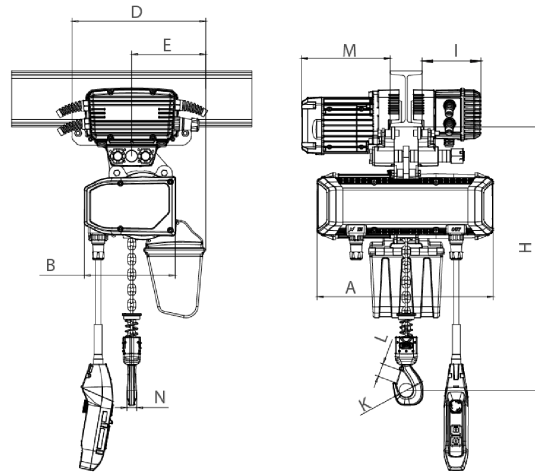

**1/2 ton Electric Chain Hoist w/
Power Trolley 2 Speed 380V 3ø
50HZ 13ft G100 Nickel Duty H4/M5**

Especificaciones Técnicas

Capacidad de Carga	1/2 ton	Altura de Izaje Estandar (Customizable)	13 ft / 4 m
Velocidad /min	1 st speed : (9.84 ft @60Hz - 2.5 mt @50Hz) / 2 nd speed : (31.49 ft @60Hz - 8 mt @50Hz)	Numero de Velocidades	2 Speed
Voltaje	3 Phase 380V 50Hz	Protección IEC Motor	IP55
Tipo Transmisión / Reductor	Spur gearbox	Tipo de Cadena	G100 Nickel
Dimensiones de la Cadena	6.3mm	Caidas de Cadena	1
Longitud de cadena	13	Humedad	20%~90%
Temperatura	-4 ~ 104° F / -20 ~ 40° C	Normas	ASME HST-1 , ASME B30.16 , EN60204-37
Garantía	3 Year	Hoist Contactors Amps	10A
Hoist Contactor Brand	Schneider	Hoist UL Components	UL Listed Contactors
Hoist Contactor Model	LC1K09008 / LC2K0910 / LC1K0910	Hoist Contactor Coil Voltage	48V
IEC Hoist IP Protection	IP55	Pendant Control Yes No	Yes
IEC Pendant Control Protection	IP66	Pendant Control Emergency Stop	Yes
Pendant Control total Length	10 ft	Hoist Motor Power in KW	0.75
Hoist Motor Brake Type and DC Voltage	DC170V	Overload Protection	Overload Motor Clutch
Hour Meter	Internal Working Hour Meter	Brake rectifiers-half-wave	PWRX-BKTF-HW
Hoist Motor Insulation Grade	F	Recommended Hoist Protection Circuit Breaker AMPs and Type	Type D 3A at 380V
Optional Load Chain Brand & Country of Origin	FEC Japan	Reducer Lubrication Type	Oil
Paint Specifications	Electrostatic Sprayed Plastic (ESP) Epoxy resins, Polyester Resins, Barium, Pigments	Load Chain weight per foot [lbs]	0.58
1st Package Type	Wood Crate	2nd Package Type	Wood Crate



Rated load (t)	Type	Dimension (mm)							
		Minimum distance from the bottom of the track to the bottom hook: H	A	L	B	D	E	I	M
0.25	PWRXT0.25-01	473	440	3500-5500	285	210	20	105	140
0.5	PWRXT0.5-01	473	440		285	210	20	105	140

Peso & Dimensiones

Peso Total 149.6 lbs / 68 Kg

Detalles del Empaque

H Altura Muerta 15.59

A Altura Total 15.59

D Depth 17.32

W Ancho 12.01

J Boca Gancho 1.38

Peso Total (sin cable o cadena) 113.49

Referential Images / Imágenes Referenciales

Specifications may change without notice / las especificaciones pueden cambiar sin previo aviso