

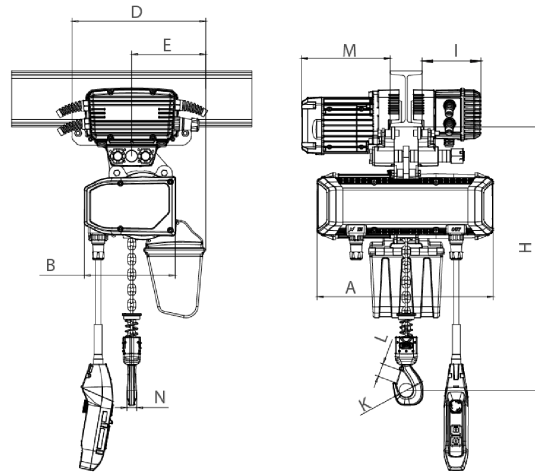

**1/2 ton Electric Chain Hoist w/
Power Trolley 1 Speed 380V 50HZ**

Especificaciones Técnicas

Plug	Open Leads	Capacidad de Carga	1/2 ton
Altura de Izaje Estandar (Customizable)	13 ft / 4 m	Velocidad /min	31.49 ft @60Hz 8 mt @50Hz
Numero de Velocidades	1 Speed	Voltaje	3 Phase 380V 50Hz
Clase de Servicio	H4/M5/2m/Class D	Protección IEC Motor	IP55
Control	Pendant Control IP66	Voltaje del Control	48V
Tipo Transmisión / Reductor	Spur gearbox	Tipo de Cadena	G100 Nickel
Dimensiones de la Cadena	6.3mm	Caidas de Cadena	1
Longitud de cadena	13	Humedad	20%~90%
Temperatura	-4 ~ 104° F / -20 ~ 40° C	Potencia del Trolley	500
Velocidad del Trolley /min	43.30 ft @60Hz 11 mt @50Hz	Cantidad de Velocidades	1
Normas	ASME HST-1 , ASME B30.16 , EN60204-37	Garantía	3 Year
Hoist Contactors Amps	10A	Hoist Contactor Brand	Schneider
Hoist UL Components	UL Listed Contactors	Hoist Contactor Model	LC1K09008 / LC2K0910
Hoist Contactor Coil Voltage	48V	IEC Hoist IP Protection	IP55
Pendant Control Yes No	Yes	IEC Pendant Control Protection	IP66
Pendant Control Emergency Stop	Yes	Pendant Control total Length	10 ft
Hoist Motor Power in KW	0.75	Hoist Motor Brake Type and DC Voltage	DC170V
Overload Protection	Overload Motor Clutch	Hour Meter	Internal Working Hour Meter
Brake rectifiers-half-wave	PWRX-BKTF-HW	Hoist Motor Insulation Grade	F
Recommended Hoist Protection Circuit Breaker AMPs and Type	Type D 10A	Optional Load Chain Brand & Country of Origin	FEC Japan
Reducer Lubrication Type	Oil	Paint Specifications	Electrostatic Sprayed Plastic (ESP) Epoxy resins, Polyester Resins, Barium, Pigments
Trolley Motor Brake Type and DC Voltage	DC170V	Trolley Motor Insulation Grade	F
Trolley Contactors Amps	20A	Trolley Contactors Brand	Schneider
Trolley UL Component	UL Listed	Trolley Contactors Model	LC1K09008
Trolley Contactors Coil Voltage	48V	Trolley Wheel Diameter	95
Trolley Wheel Material	No. 45 steel	Trolley Minimum Turn Radius	1.3 m / 4.2 ft
Trolley Beam Range	3" to 5"	Trolley Beam Extension Kit	up to 12"
Load Chain weight per foot [lbs]	0.36	1st Package Type	Wood Crate
2nd Package Type	Wood Crate		



Rated load (t)	Type	Dimension (mm)							
		Minimum distance from the bottom of the track to the bottom hook: H	A	L	B	D	E	I	M
0.25	PWRXT0.25-01	473	440	3500-5500	285	210	20	105	140
0.5	PWRXT0.5-01	473	440		285	210	20	105	140

Peso & Dimensiones

Peso Total 145.2 lbs / 66 Kg

Detalles del Empaque

H Altura Muerta 15.59

A Altura Total 15.59

D Depth 17.32

W Ancho 12.01

J Boca Gancho 1.38

Peso Total (sin cable o cadena) 116.28

Referential Images / Imágenes Referenciales

Specifications may change without notice / las especificaciones pueden cambiar sin previo aviso