

**20 ton Electric Chain Hoist 1 Speed
380V 3ø 50HZ**

Especificaciones Técnicas

Capacidad de Carga	20 ton	Altura de Izaje Estandar (Customizable)	40 ft / 12 m
Velocidad /min	5.31 ft @60Hz 1.35 mt @50Hz	Numero de Velocidades	1 Speed
Voltaje	3 Phase 380V 50Hz	Clase de Servicio	H4/M5/2m/Class D
Protección IEC Motor	IP55	Control	Pendant Control IP66
Voltaje del Control	24V	Tipo Transmisión / Reductor	Spur gearbox
Tipo de Cadena	G100 Nickel	Dimensiones de la Cadena	11.2 mm
Caidas de Cadena	8	Longitud de cadena	320
Humedad	20%~90%	Temperatura	-4 ~ 104° F / -20 ~ 40° C
Normas	ASME HST-1 , ASME B30.16 , EN60204-39	Garantía	3 Year
Hoist Contactors Amps	25A	Hoist Contactor Brand	Schneider
Hoist Contactor Model	LC1D25B7C	Hoist Contactor Coil Voltage	24 V
IEC Hoist IP Protection	IP55	Pendant Control Yes No	Yes
IEC Pendant Control Protection	IP66	Pendant Control Emergency Stop	Yes
Pendant Control total Length	37 ft	Hoist Motor Power in KW	3+3
Hoist Motor Brake Type and DC Voltage	DC170V	Overload Protection	Overload Motor Clutch
Hour Meter	Internal Working Hour Meter	Brake rectifiers-half-wave	PWRX-BKTF-HW
Hoist Motor Insulation Grade	F	Recommended Hoist Protection Circuit Breaker AMPs and Type	Type D 16A at 380V
Optional Load Chain Brand & Country of Origin	FEC Japan	Reducer Lubrication Type	Oil
Paint Specifications	Electrostatic Sprayed Plastic (ESP) Epoxy resins, Polyester Resins, Barium, Pigments	Load Chain weight per foot [lbs]	1.83
1st Package Type	Wood Crate		

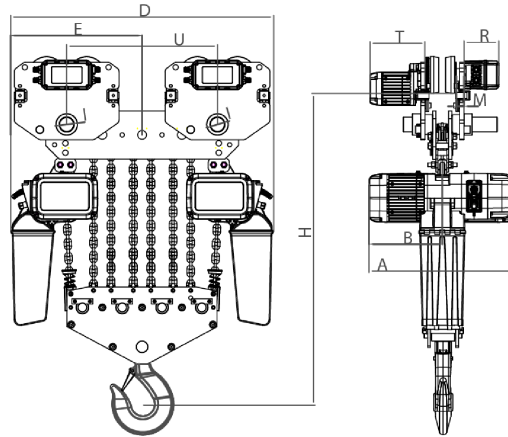

Rated load (t)	Type	Dimension (mm)												
		Minimum distance from the bottom of the track to the bottom hook: H	A	L	B	D	E	I	M	N	K	L	T	R
20	PWRXT20-08	1300	700	3500-5500	350	1246	623	71	40	80	120	96	242	167

Peso & Dimensiones

Peso Total 1474 lbs / 669 Kg

Detalles del Empaque

H Altura Muerta 48.82

A Altura Total 50

D Depth 27.56

W Ancho 49.21

J Boca Gancho 4.72

Peso Total (sin cable o cadena) 669.76

Referential Images / Imágenes Referenciales
Specifications may change without notice / las especificaciones pueden cambiar sin previo aviso