

Tecle Cadena Neumatico de 50 tons de Capacidad

Características Esenciales

- 50 Tons Pneumatic Chain Hoist - Heavy Duty - Explosion Proof
- RUD G80 chain made in Germany (Lifting heights upon request)
- Includes: Overload Protection - Slip Clutch / Failsafe Automatic Internal Break / Pendant Control with emergency stop / Chain containers
- Meets and exceeds ASME B30.16 / HST-5 standards / Load Test at 130% SWL / ATEX Directive

Especificaciones Técnicas

Capacidad de Carga	50 Ton	Altura de Izaje Estandard (Customizable)	66 ft / 20 m
Numero de Velocidades	1 Speed	Protección Antiexplosión	- EX 2 GD IIA T4 - EX 2 GD IIB T4 - EXCLUDES Hydrogen Disulphide or Ethelene Oxide - ZONES 1, 2 AND 21, 22
Clase de Servicio	100% Duty Cycle	Freno Motor	>125% WLL Automatic self-adjusting multidisc Brake
Control	Pendant Control w/emergency stop	Tipo Transmisión / Reductor	Epicycle Gearbox (Grease Filled and Sealed)
Tipo de Cadena	G80 RUG Germany 5:1 Safety Factor	Dimensiones de la Cadena	23.5 x 66 mm
Caidas de Cadena	4	Temperatura	-20°C to 70°C
Nivel de Ruido	84 dBA @ 1m	Normas	ASME B30.11 /B30.16 /HST-5 DIN EN818-7 SANS 1638 compliant ATEX EX Classification according to EC Directive on Hazardous Locations 94/9/EEC
Fabricado en	South Africa	Garantía	3 Year
Pendant Control Yes No	Included	IEC Pendant Control Protection	IP66
Pendant Control Emergency Stop	Yes		

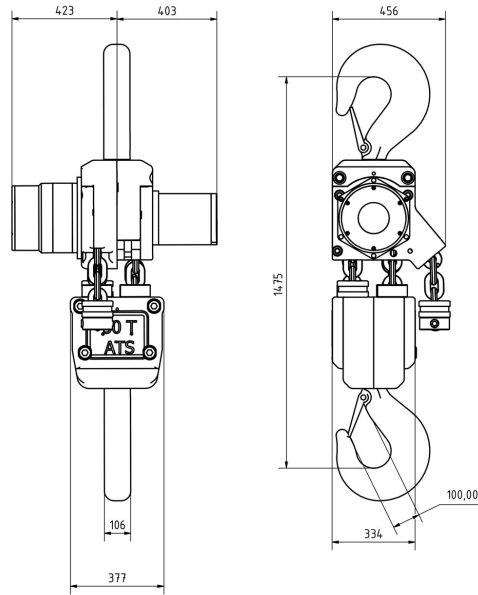

Dimensions in mm/ Dimensiones en mm

Detalles del Empaque

H Altura Muerta

59.44

Referential Images / Imágenes Referenciales
Specifications may change without notice / las especificaciones pueden cambiar sin previo aviso