

2000 lb 1 Speed Electric Chain Hoist 20ft G100 Chain M4/H3 380V UL Wireless

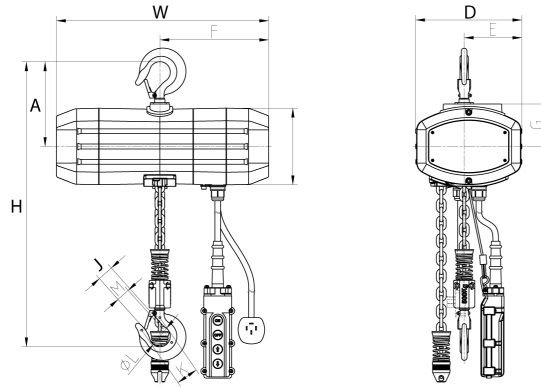

Especificaciones Técnicas

Capacidad de Carga	2200 lb / 1000 kg	Plug	Open Leads
Altura de Izaje Estandard (Customizable)	20 ft / 6 m	Velocidad /min	16 ft / 5.0 m
Numero de Velocidades	1 Speed	Voltaje	3 Phase 380V 50Hz
Clase de Servicio	H3/M4/1Am/Class C	Freno Motor	Yes DC Electromagnetic
Protección IEC Motor	IP55	Control	Wireless and Pendant Control
Voltaje del Control	24V	Tipo de Cadena	G100
Dimensiones de la Cadena	8x24 mm	Caidas de Cadena	1
Longitud de cadena	20 ft / 6 m	Humedad	<85%
Temperatura	-4 ~ 104° F / -20 ~ 40° C	Nivel de Ruido	81 dB
Normas	UL 1340 - ASME HST-1 , ASME B30.16 , EN60204-32	UL File	MSXT.E528915 - Hoists
Garantía	3 Year	Pendant Control Yes No	Included
IEC Pendant Control Protection	IP66	Pendant Control Emergency Stop	Yes



Peso & Dimensiones

Peso Total

155 lbs / 71 Kg

Referential Images / Imágenes Referenciales
Specifications may change without notice / las especificaciones pueden cambiar sin previo aviso