



Polipasto Cadena con Carro - Neumatico Anti explosion de 1,5 Tons ATEX

Características Esenciales

- 1.5 Tons Pneumatic Chain Hoist with trolley - Heavy Duty - Explosion Proof
- RUD G80 chain made in Germany - 9 meters lifting height (other heights available upon request) Safety factor 5:1
- Includes: Multi-disc slip clutch load limiter / Pendant Control with emergency stop (8 meters) / Chain containers
- Meets and exceeds ASME B30.16 B30.17 / HST-5 standards / Load Test at 130% SWL / ATEX Directive

Especificaciones Técnicas

Capacidad de Carga	1.5 Ton	Altura de Izaje Estandar (Customizable)	20 ft / 6 m
Numero de Velocidades	1 Speed	Protección Antiexplosión	EX 2 GD IIA T4 EX 2 GD IIB T4 EX 2 GD IIC T4 ZONES 1, 2 AND 21, 22 - Copper Coated: Chain hook, bottom block, Sprocket, Load sleeve, Safety Catch - Stainless Steel Wheels
Clase de Servicio	100% Duty Cycle	Freno Motor	>125% WLL Automatic self-adjusting multidisc Brake
Control	Pendant Control 4 buttons w/emergency stop	Tipo Transmisión / Reductor	Epicycle Gearbox (Grease Filled and Seald)
Tipo de Cadena	G80 RUD Germany 5:1 Safety Factor	Dimensiones de la Cadena	9 x 27 mm
Caidas de Cadena	1	Longitud de cadena	9 m
Potencia del Trolley	0.3 kW	Nivel de Ruido	84 dBA @ 1m
Velocidad del Trolley /min	12 m/min	Cantidad de Velocidades	1
Rango de ancho de la Viga	65 - 280 mm	Radio Mínimo de Giro	1.5 m
Normas	ASME B30.11 / B30.16 / B30.17 / HST-5 DIN EN818-7 SANS 1638 compliant ATEX EX Classification according to EC Directive on Hazardous Locations 94/9/EEC	Fabricado en	Southafrica
Garantía	3 Year		

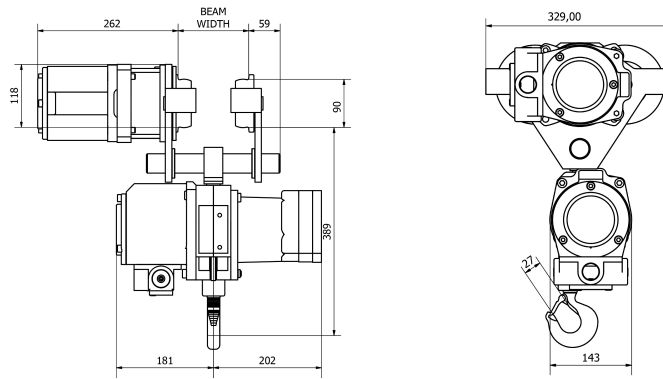

Detalles del Empaque

H Altura Muerta

15.83

Referential Images / Imágenes Referenciales
Specifications may change without notice / las especificaciones pueden cambiar sin previo aviso