

1 Ton Underhung Motorized End Trucks Single Girder up to 57ft Span 220/440V 3P

Características Esenciales

- I Beam and H Beam Compatible, Customizable up to 12" width Beams
- Kit Includes 2 End Trucks, 4 motors, 4 reducer, 4 Brakes
- Dual Voltage 220/440V 3 Phase, Optional Variable Speed Driver
- Fully Painted Orange RAL2009

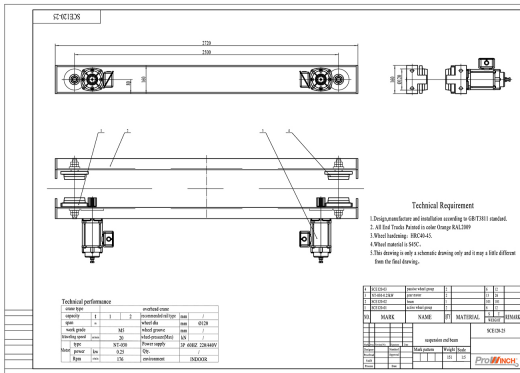

Especificaciones Técnicas

| | | | |
|------------------------------|-----------------------------------|-----------------------------|-----------------------|
| Capacidad de Carga | 1 ton | Velocidad /min | 66 ft |
| Numero de Velocidades | 1 Speed - Optional Variable Speed | Voltaje | 3 Phase 240/480V 60Hz |
| Luz Maxima | 70 ft | Material | Steel |
| Clase de Servicio | H4/M5/2m/Class D | Protección IEC Motor | IP54 |
| Normas | ASME / CMAA / Nch | Garantía | 3 Year |
| Largo de testera | 2500 mm | | |

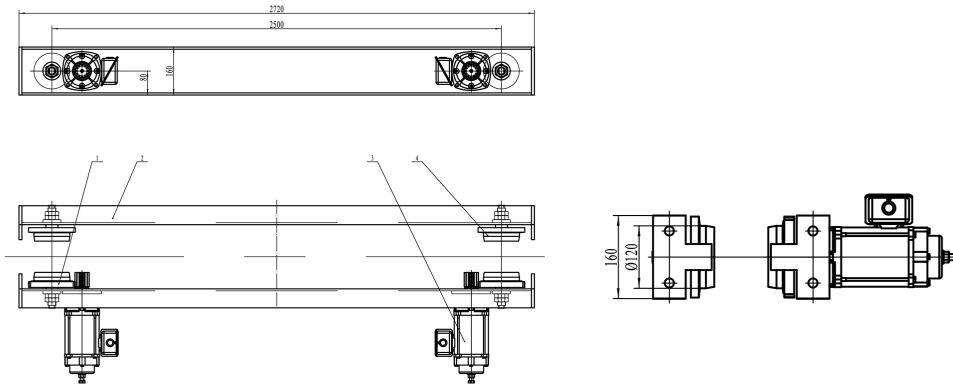

Peso & Dimensiones

Peso Total

784 lbs / 356 Kg

Referential Images / Imágenes Referenciales
Specifications may change without notice / las especificaciones pueden cambiar sin previo aviso